



IR3000V @ 900 V<sub>dc</sub>

IR3000V @ 1800 V<sub>dc</sub>

## IR3000V line

### Applications

On the roof under frame

On board

The IR3000V series are single pole, magnetic blow out, trip free, air circuit breakers.

The closing mechanism is an independent motor operated type.

The IR3000V Circuit Breaker is held closed by holding coil or by permanent magnet device and is equipped with a direct acting over-current trip device which may be either unidirectional and bidirectional.

The arc chute is made in ceramic material for a longer life and reduced maintenance.

The use of arching contacts ensure a long duration in electrical life.

The IR3000V is available in a IP45 plastic box or IP55 metallic box.

The breaker conforms to EN60077.

# HSCBs

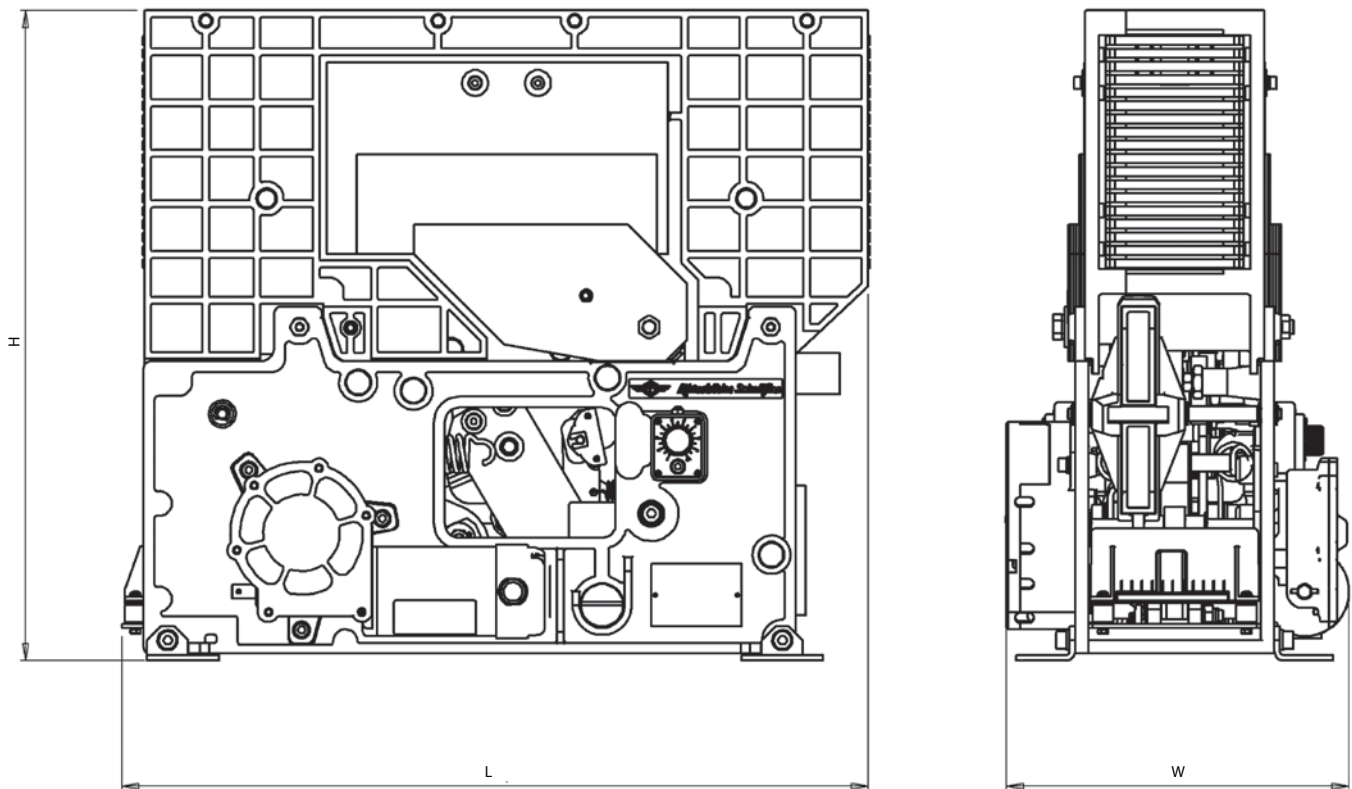

Type [ $V_{dc}$ ]	$U_{max}$ [V]	I [A]	W [mm]	H [mm]	L [mm]
IR3015V @ 900	900	1500	250,5	395	546,5
IR3015V @ 1800	1800	1500	250,5	478	546,5
IR3030V @ 900	900	3000	250,5	395	546,5
IR3030V @ 1800	1800	3000	250,5	478	546,5

# IR4000 line

## Applications

On the vehicle roof

Under vehicle frame

Inside the loco cubicle

DC Substation

Industry

The IR4000 Line is single pole air High Speed Circuit Breakers for DC applications with rated voltages of 900, 1800 or 3600 Vdc and thermal currents up to 4,5kA.

Based on ceramic fins technology, IR4000 are designed to protect the downstream power circuits from overcurrent and short circuit.

The IR4000 Circuit Breaker is an independent motor operated type and held close by holding coil or permanent magnet. It is the latest generation of the well-known IR6000 line because it integrates all improvements resulting from a long experience in many worldwide rail and industry applications. It replaces easily the first generation IR6000 for both electrical and mechanical aspects.

A compact and robust platform allows to withstand very harsh conditions in order to face all working requirement for onboard applications (IR4000V) as well as fixed installations (IR4000F).

The IR4000 Line is the right solution if high or very high power load protection is required.

In order to fit limited space available on vehicles the IR4000 can be mounted:

- Inside the cubicle in vertical mounting position : IR4000VV
- Under the frame as well as on the roof in horizontal mounting position: IR4000VH

## Standard Characteristics

- Thermal current rating 3000 or 4500A.
- Rated voltages of 900, 1800 or 3600 Vdc
- Single pole, magnetic blow out, trip free, air circuit breakers
- The closing motor is an independent motor operated type.
- Held closed by holding coil or permanent magnet device.
- Bidirectional direct acting over-current trip device.
- Ceramic arc chute guarantees a longer life and reduced maintenance.
- Arcing contacts ensure a long duration in electrical life.
- Reed type auxiliary contacts

## Customization Available

- Monodirectional direct acting over-current trip device.
- Dual voltage arc chute
- IP65 Metal enclosure for roof or under frame application
- Fast opening device for fixed application

# HSCBs

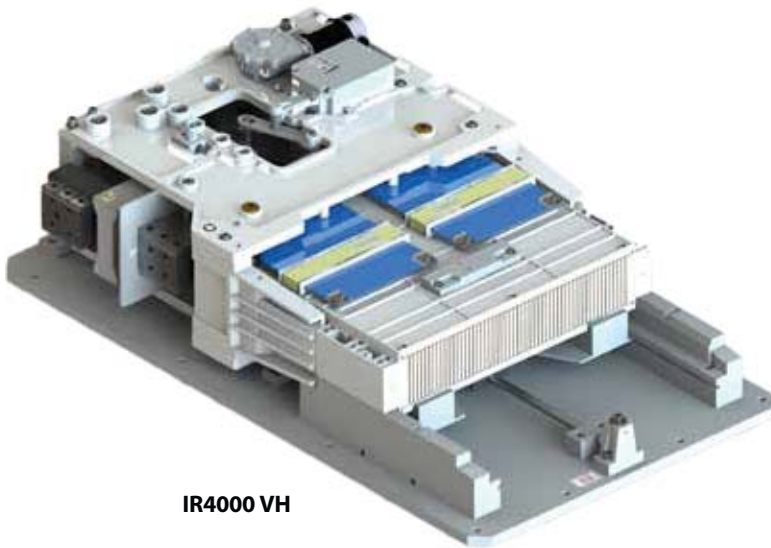

**IR4000 VH**



**IR4000 VV and IR4000 F**

On Board application					Max Breaking current (kA/ms) according to IEC60077	
	IR4000 V Line	Version	I <sub>th</sub> (A) @ 75°C	U <sub>e</sub> (Vdc) = 1800Vdc	U <sub>e</sub> (Vdc) = 3600Vdc	
	IR4030VV18M	Very High Power	3000	90 / 0 60 / 15 50 / 40 35 / 100	-	
	IR4045VV18M	Very High Power	4500	-	-	
	IR4030VV36M	Very High Power	3000	-	55 / 0 50 / 15 50 / 30 50 / 50	
	IR4045VV36M	Very High Power	4500	-	-	
	IR4030VH18M	Very High Power	3000	90 / 0 60 / 15 50 / 40 35 / 100	-	
	IR4045VH18M	Very High Power	4500	-	-	
	IR4030VH36M	Very High Power	3000	-	55 / 0 50 / 15 50 / 30 50 / 50	
IR4045VH36M	Very High Power	4500	-	-		



IR6000V Roof Mounting

## IR6000V line

### Applications

Vehicles

The IR6000V series are single pole, magnetic blow out, trip free, air circuit breakers.

The closing mechanism is an independent motor operated type.

The IR6000 Circuit Breaker is held closed by holding coil or by permanent magnet device and is equipped with a direct acting over-current trip device which may be either unidirectional and bidirectional.

The arc chute is made in ceramic material for a longer life and reduced maintenance.

The use of arcing contacts ensure a long duration in electrical life.

The breakers can be used in single voltage or dual voltage applications, where multisystem solution is required (ex 1800/3600V).

The breaker conforms to EN60077.

# HSCBs



**IR6000V Vertical**

**Overall Dimensions: mm**

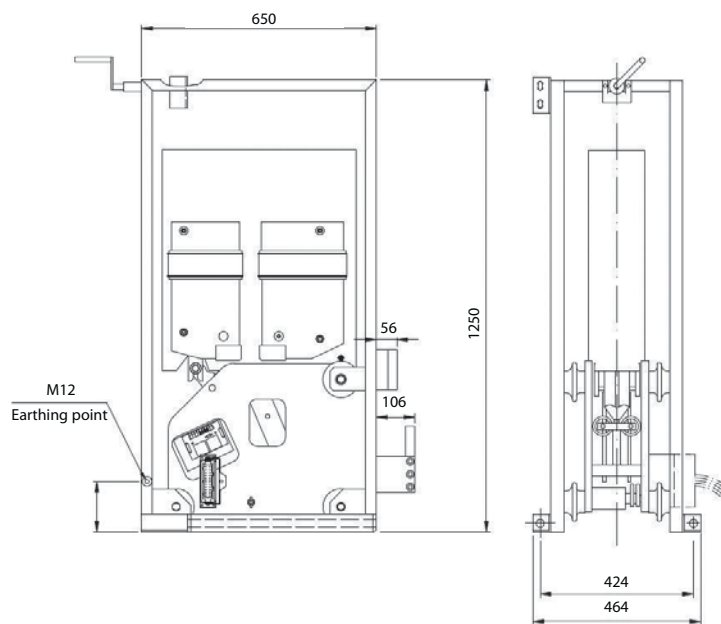

Type	U <sub>max</sub> [V]	I [A]	W [mm]	H [mm]	L [mm]
<b>IR6000 Vertical</b>	up to 3600	4000	464	1250	650
<b>IR6000 Horizontal</b>	up to 3600	2500	470	680	1200
<b>IR6000 Roof</b>	up to 3600	2500	560	525	1600